

# HEAVY DUTY AGM DUAL PURPOSE BATTERY

LPM12-170HD (12V170Ah)



## CHARACTERISTICS

Item	Specifications	
Nominal Voltage	12V	
Nominal Capacity (20HR)	170Ah	
Reserve Capacity	380min	
Cold Cranking Amps@0°F (-18°C)	900A	
Dimension	Length	512mm (20.2inches)
	Width	222mm (8.74inches)
	Container Height	196mm (7.72inches)
	Total Height (with Terminal)	216mm (8.50inches)
Approx Weight	50.5kg (111.3lbs)	
Terminal	5	
Cell layout	3	
Hold-Down	B0	
Case	Black-PP Material	
Cover	Black-PP Material	
Handle	TS8	

## APPLICATIONS

- Parking air-conditioner
- Commercial vehicle start
- Engine start

## GENERAL FEATURES

- Superior deep cycle performance
- Excellent start ability
- Super capacity reach 330Ah
- VRLA and maintenance-free design
- Excellent vibration resistance – EN V4
- High charge acceptance, fast recharge
- OE quality certification

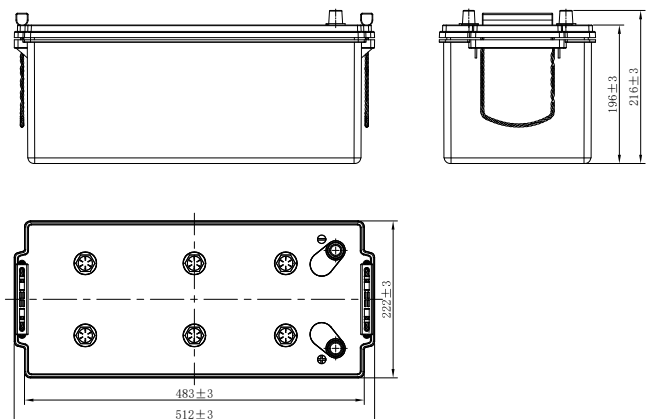
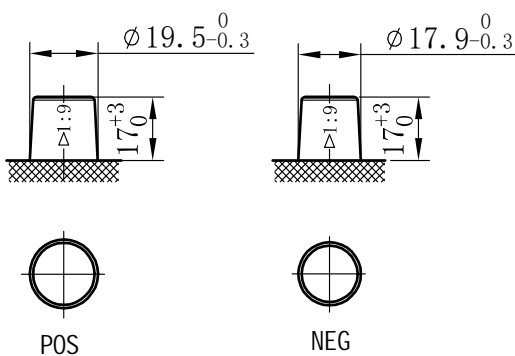

\*Values are subject to variation of +/- 5% in normal manufacturing processes.

Leoch International Technology Ltd.  
[www.leoch.com](http://www.leoch.com)

Leoch Batteries Pte Ltd  
[www.leoch.sg](http://www.leoch.sg)

Leoch Battery Corporation  
[www.leochamericas.com](http://www.leochamericas.com)

Leoch Europe S.A.  
[www.leoch.eu](http://www.leoch.eu)